

SYMBOL	~	▽	▽▽	▽▽▽	▽▽▽▽
Ra μm	50	25 12.5	6.3 3.2 1.6	0.8 0.4	0.2 0.1

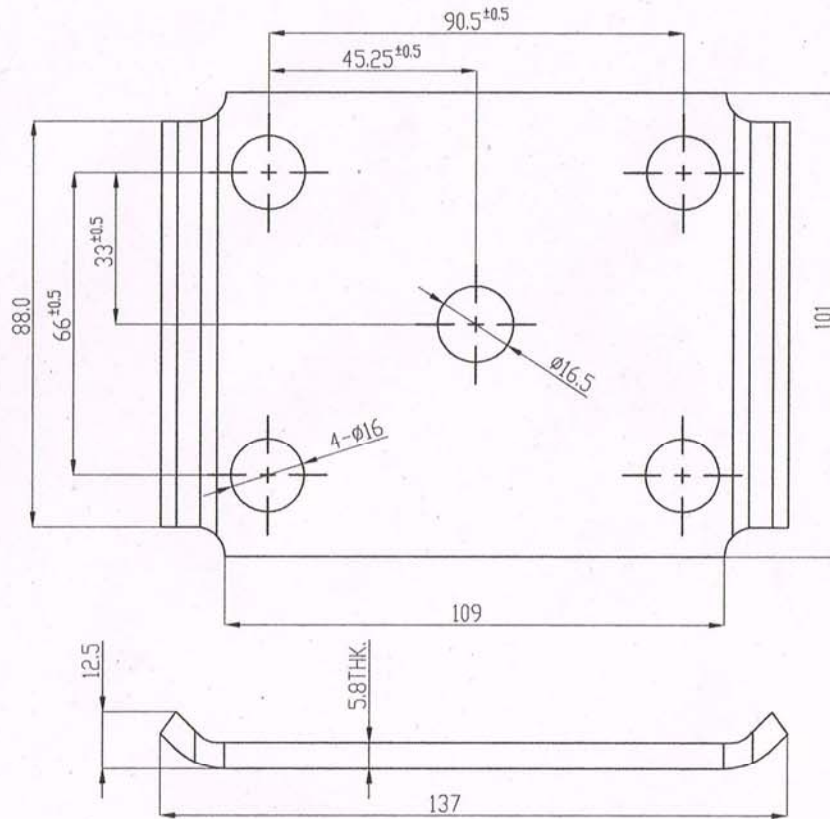

NOTE:-

1. Unspecified Tol. plz follow below chart for sheet metal in very coarse & for machining medium.

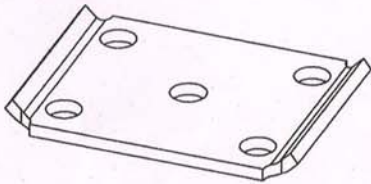

Tolerance Specified as per IS:2102 1993 Part-1				
Linear General Tolerance				
Linear Dimension	Fine	Medium	Coarse	Very Coarse
0.5 - 3"	±0.05	±0.1	±0.2	±0.5
>3 - 6"	±0.05	±0.1	±0.3	±0.5
>6 - 30"	±0.10	±0.2	±0.5	±1.0
>30 - 120"	±0.15	±0.3	±0.8	±1.5
>120 - 400"	±0.20	±0.5	±1.2	±2.5
>400 - 1000"	±0.30	±0.8	±2.0	±4.0
>1000 - 2000"	±0.50	±1.2	±3.0	±6.0
Angular Dimension	Fine	Medium		
UP TO 10°	±1°	±1°	±1° 30'	±3°
>10 - 50°	±0° 30'	±0° 30'	±1°	±2°
>50 - 120°	±0° 20'	±0° 20'	±0° 30'	±1°
>120 - 400°	±0° 10'	±0° 10'	±0° 15'	±0° 30'
400°	±0° 5'	±0° 5'	±0° 10'	±0° 20'

PART NAME	HANGER PLATE FOR TRAILER KIT		
ITEM CODE	TRPL003		
MATERIAL	L.C		
FINISH			
SCALE	N.T.S.		
DRAWING No.			
WEIGHT.	0.565 Kg	A4	

LOT No.

SYMBOL	~	▽	▽▽	▽▽▽	▽▽▽▽
Ra μm	50	25 12.5	6.3 3.2 1.6	0.8 0.4	0.2 0.1

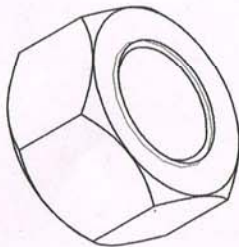
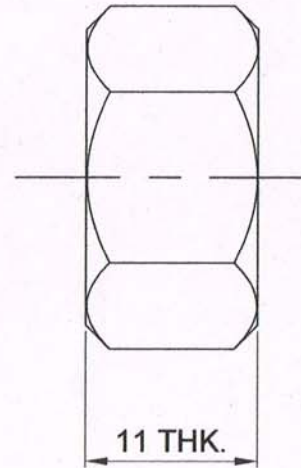
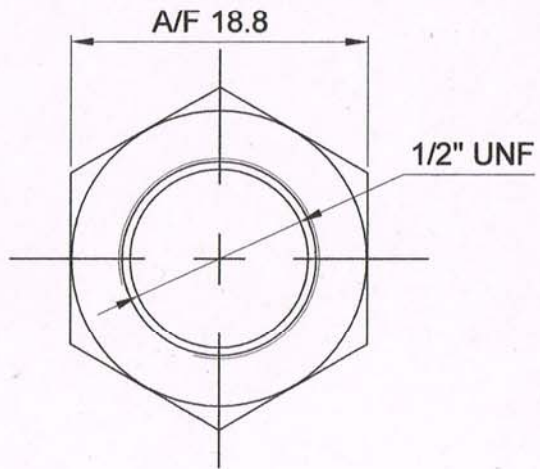

NOTE:-

1. Unspecified Tol. plz follow below chart for sheet metal in very coarse & for machining medium.

Tolerance Specified as per IS:2102 1993 Part-1				
Linear General Tolerance				
Linear Dimension	Fine	Medium	Coarse	Very Coarse
0.5 - 3"	±0.05	±0.1	±0.2	
>3 - 6	±0.05	±0.1	±0.3	±0.5
>6 - 30	±0.10	±0.2	±0.5	±1.0
>30 - 120	±0.15	±0.3	±0.8	±1.5
>120 - 400	±0.20	±0.5	±1.2	±2.5
>400 - 1000	±0.30	±0.8	±2.0	±4.0
>1000 - 2000	±0.50	±1.2	±3.0	±6.0
Angular Dimension	Fine	Medium		
UP TO 10	±1°	±1°	±1° 30'	±3°
>10 - 50	±0° 30'	±0° 30'	±1°	±2°
>50 - 120	±0° 20'	±0° 20'	±0° 30'	±1°
>120 - 400	±0° 10'	±0° 10'	±0° 15'	±0° 30'
400	±0° 5'	±0° 5'	±0° 10'	±0° 20'

PART NAME	NUT FOR TRAILER KIT		
ITEM CODE	TRN 1/2		
MATERIAL	L.C.		
FINISH			
SCALE	N.T.S.		
DRAWING No.			
WEIGHT.	0.015 Kg/Pc	A4	

LOT No.

SYMBOL	~	▽	▽▽	▽▽▽	▽▽▽▽
Ra μm	50	25 12.5	6.3 3.2 1.6	0.8 0.4	0.2 0.1

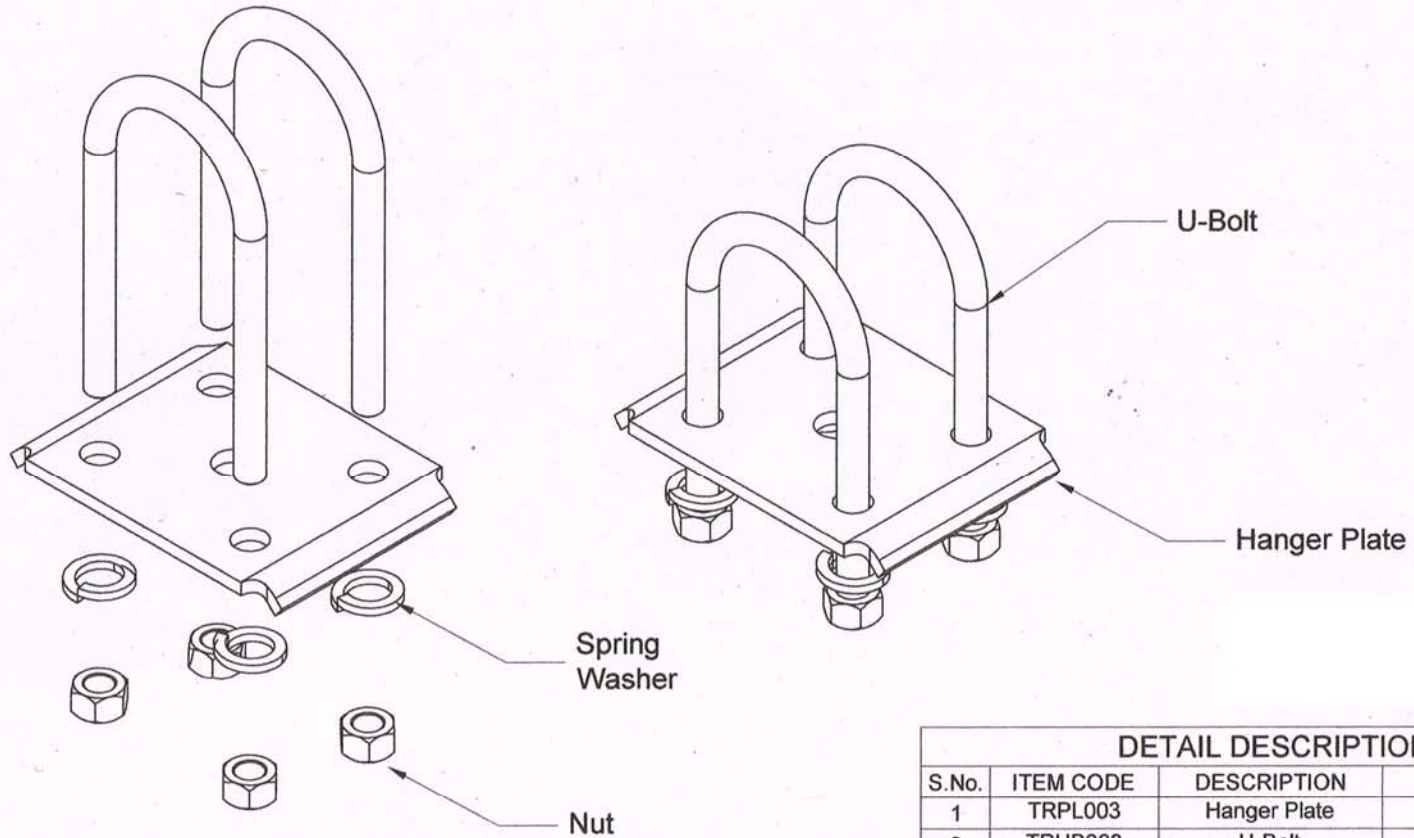

DETAIL DESCRIPTION				
S.No.	ITEM CODE	DESCRIPTION	FINISH	QTY.
1	TRPL003	Hanger Plate		2
2	TRUB003	U-Bolt		4
3	TRN 1/2	Nut		8
4	TRW217	Spring Washer	White Z.P.	8

Tolerance Specified as per IS:2102 1993 Part-1				
Linear General Tolerance				
Linear Dimension	Fine	Medium	Coarse	Very Coarse
0.5 - 3"	±0.05	±0.1	±0.2	
>3 - 6	±0.05	±0.1	±0.3	±0.5
>6 - 30	±0.10	±0.2	±0.5	±1.0
>30 - 120	±0.15	±0.3	±0.8	±1.5
>120 - 400	±0.20	±0.5	±1.2	±2.5
>400 - 1000	±0.30	±0.8	±2.0	±4.0
>1000 - 2000	±0.50	±1.2	±3.0	±6.0
Angular Dimension	Fine	Medium		
UP TO 10	±1°	±1°	±1° 30'	±3°
>10 - 50	±0° 30'	±0° 30'	±1°	±2°
>50 - 120	±0° 20'	±0° 20'	±0° 30'	±1°
>120 - 400	±0° 10'	±0° 10'	±0° 15'	±0° 30'
400	±0° 5'	±0° 5'	±0° 10'	±0° 20'

PART NAME	TRAILER KIT 3"		
ITEM CODE	TRKTTK3		
MATERIAL	AS PER PART DRAWING		
FINISH	AS PER DRAWING		
SCALE	N.T.S.		
DRAWING No.		A4	⊙ ◻
WEIGHT.	2.740 Kg		

LOT No.

SYMBOL	~	▽	▽▽	▽▽▽	▽▽▽▽
Ra μm	50	25 12.5	6.3 3.2 1.6	0.8 0.4	0.2 0.1

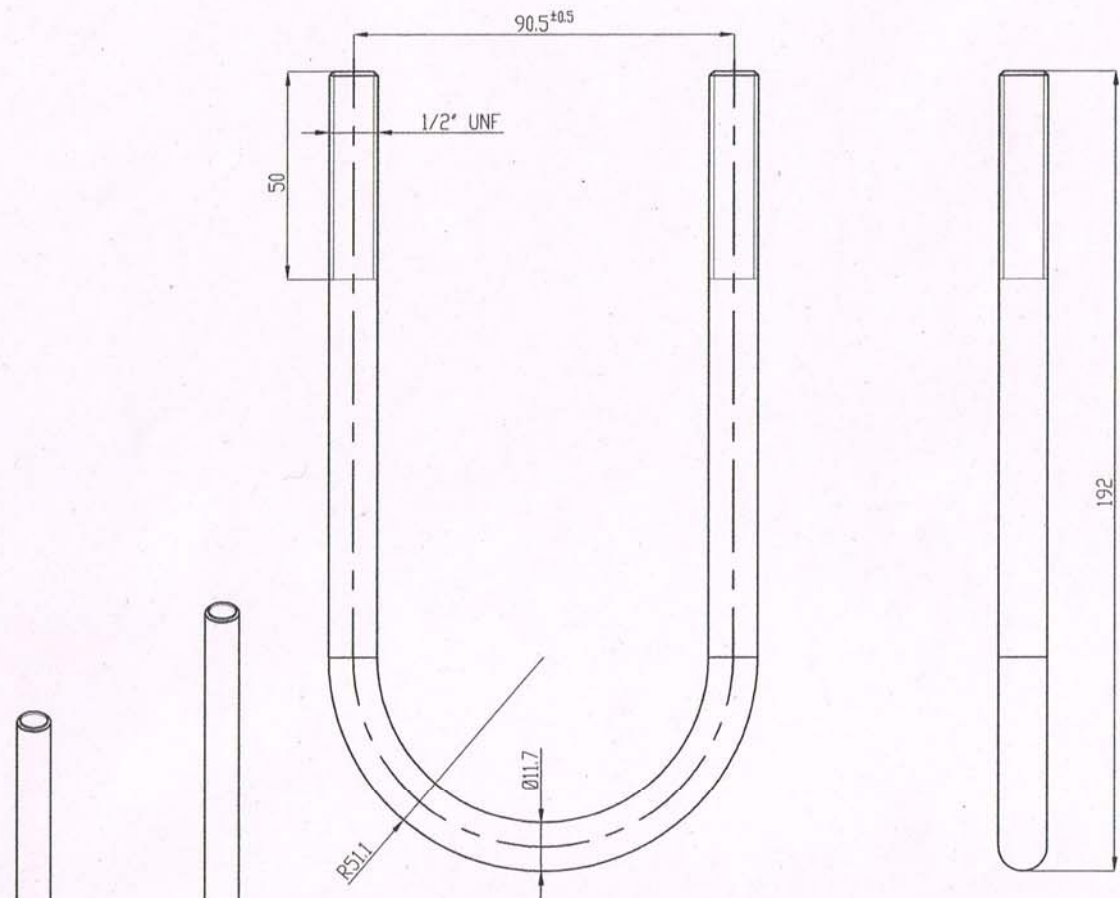

NOTE:-  
1. Unspecified Tol. plz follow below chart for sheet metal in very coarse & for machining medium.

Tolerance Specified as per IS:2102 1993 Part-1				
Linear General Tolerance				
Linear Dimension	Fine	Medium	Coarse	Very Coarse
0.5 - 3*	±0.05	±0.1	±0.2	
>3 - 6	±0.05	±0.1	±0.3	±0.5
>6 - 30	±0.10	±0.2	±0.5	±1.0
>30 - 120	±0.15	±0.3	±0.8	±1.5
>120 - 400	±0.20	±0.5	±1.2	±2.5
>400 - 1000	±0.30	±0.8	±2.0	±4.0
>1000 - 2000	±0.50	±1.2	±3.0	±6.0
Angular Dimension	Fine	Medium		
UP TO 10	±1°	±1°	±1° 30'	±3°
>10 - 50	±0° 30'	±0° 30'	±1°	±2°
>50 - 120	±0° 20'	±0° 20'	±0° 30'	±1°
>120 - 400	±0° 10'	±0° 10'	±0° 15'	±0° 30'
400	±0° 5'	±0° 5'	±0° 10'	±0° 20'

PART NAME	U-BOLT FOR TRAILER KIT		
ITEM CODE	TRUB003		
MATERIAL	L.C		
FINISH			
SCALE	N.T.S.		
DRAWING No.			
WEIGHT.	0.360 Kg/Pc	A4	⊙ □

LOT No.

<b>SYMBOL</b>	~	▽	▽▽	▽▽▽	▽▽▽▽
<b>Ra μm</b>	50	25 12.5	6.3 3.2 1.6	0.8 0.4	0.2 0.1

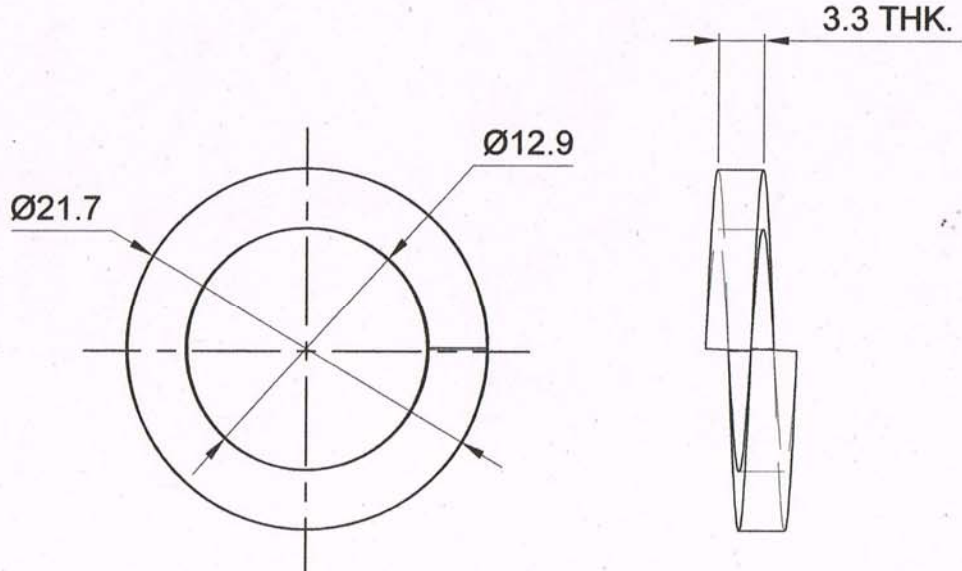

NOTE:-

1. Unspecified Tol. plz follow below chart for sheet metal in very coarse & for machining medium.

Tolerance Specified as per IS:2102 1993 Part-1				
Linear General Tolerance				
Linear Dimension	Fine	Medium	Coarse	Very Coarse
0.5 - 3"	±0.05	±0.1	±0.2	±0.5
>3 - 6	±0.05	±0.1	±0.3	±0.5
>6 - 30	±0.10	±0.2	±0.5	±1.0
>30 - 120	±0.15	±0.3	±0.8	±1.5
>120 - 400	±0.20	±0.5	±1.2	±2.5
>400 - 1000	±0.30	±0.8	±2.0	±4.0
>1000 - 2000	±0.50	±1.2	±3.0	±6.0
Angular Dimension	Fine	Medium		
UP TO 10	±1°	±1°	±1° 30'	±3°
>10 - 50	±0° 30'	±0° 30'	±1°	±2°
>50 - 120	±0° 20'	±0° 20'	±0° 30'	±1°
>120 - 400	±0° 10'	±0° 10'	±0° 15'	±0° 30'
400	±0° 5'	±0° 5'	±0° 10'	±0° 20'

<b>PART NAME</b>	WASHER FOR TRAILER KIT
<b>ITEM CODE</b>	TRW217
<b>MATERIAL</b>	SPRING STEEL
<b>FINISH</b>	WHITE Z.P.
<b>SCALE</b>	N.T.S.
<b>DRAWING No.</b>	
<b>WEIGHT.</b>	0.006 Kg/Pc

LOT No.

A4

